

The 4 Phases of Phobos

Wit Busza

PHOBOS

NASA/JPL/ARIZONA UNI

Phobos a Success Story for

- The RHIC Management
- The PAC
- The Accelerator Department
- The DoE
- HEP/NP Collaboration
- The Phobos Collaboration



Origins of PHOBOS Collaboration

- **NP**: Phase Diagram and Properties of Hot QCD Matter ?
- **HEP**: Mechanism of Multiparticle Production ?

Physics Expectations and Prejudices in late 1980's and early 1990's were very different from those today. We were driven by the possibility that there will be a

- Discontinuity of observables as a function of energy and system size
- Very significant increase in multiplicity and expansion of produced system
- Possible production of disoriented chiral condensate & of large number of very low p_T particles

Management showed wisdom & foresight to encourage a highly varied research program, including large & small experiments

Sept 1990
Proposal presented

Letter of Intent to construct

MARS

a Modular Array for RHIC Spectra

D. Beavis, A. Carroll, C. Chasman, Z. Chen, Y.Y. Chu, S. Gushue, O. Hansen,
B. Moskowitz, L.P. Remsberg, F. Videbaek, H.E. Wegner
Brookhaven National Laboratory

C. Halliwell, D. McLeod
University of Illinois at Chicago

R. Holynski, A. Trzubek, H. Wilczynski, W. Wolter, B. Wosiek
Institute of Nuclear Physics, Krakow

P. R. Hobson, D. Imrie
Brunel, The University of West London

W. Busza*, B. Cole, W. L. Kehoe, A. Konstantinidis, R. Ledoux, R. Morse,
S.G. Steadman, G.S.F. Stephans, B. Wadsworth, D. Woodruff
Massachusetts Institute of Technology

* Spokesperson



Main Properties

- ➔ Detects all charged particles near $y = 0$
- ➔ Excellent particle identification and momentum resolution for $p \leq 1.4 \text{ GeV}/c$
- ➔ Low p_t cut-off $\approx 30 \text{ MeV}/c$
- ➔ Measures global variables: $\frac{d\sigma}{dn_c}$, $\frac{dn_c}{d\eta}$, forward neutron energy
- ➔ Superb pattern recognition
- ➔ Can handle any conceivable particle densities
- ➔ Robust
- ➔ Flexible

PAC came to our rescue by rejecting this proposal

WHY 2π AZIMUTHAL COVERAGE?

From MARS Proposal:

Examples:

1.

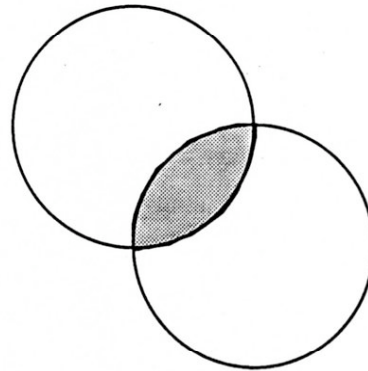

Typical collision

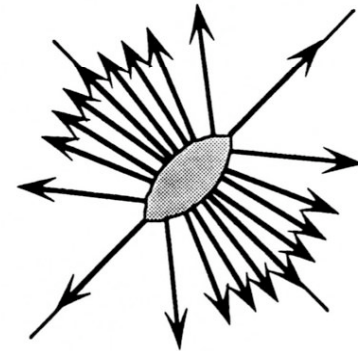

Distribution
reflects
geometry

- Asymmetry in ϕ distribution?
- Different size in 2 directions?
- Different p_t distributions in 2 directions?

2. ϕ fluctuations for central collisions?

Then study events with asymmetries

Fermilab E178 (PR D22 (1980) 13)

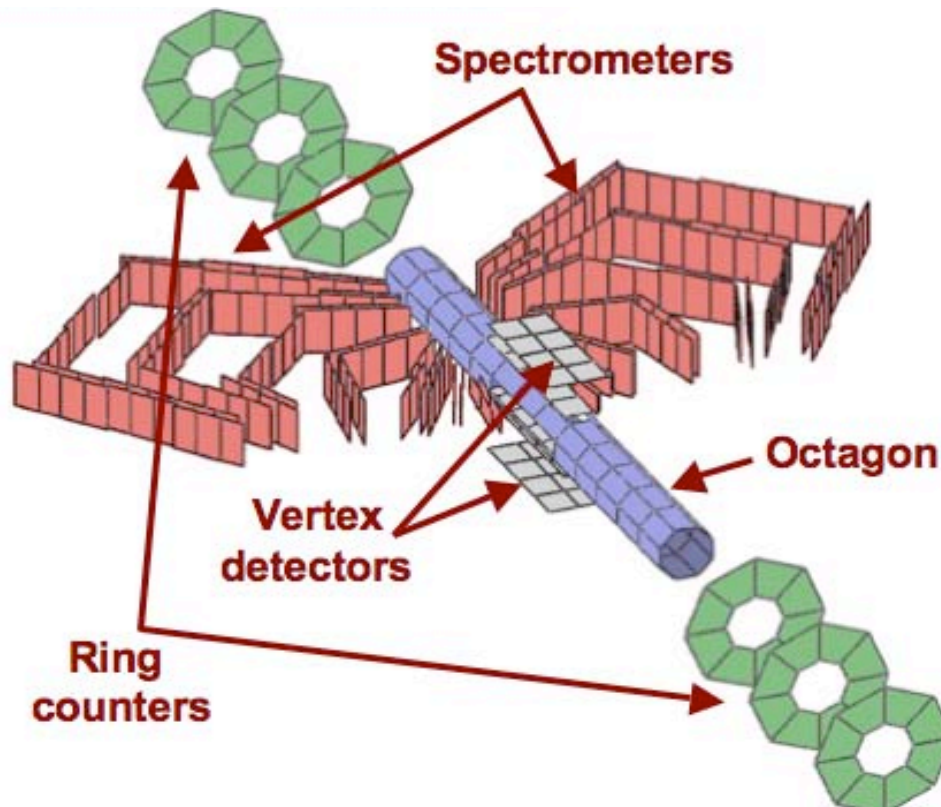
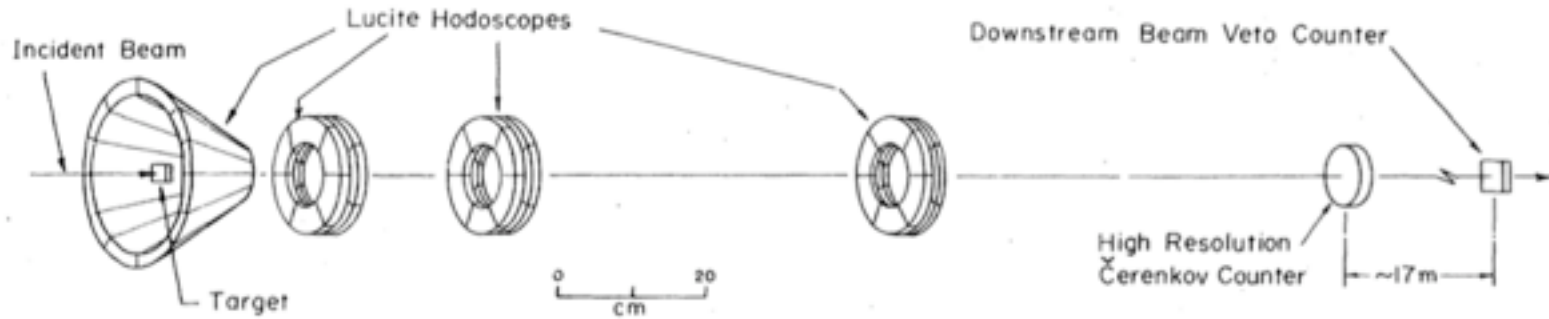

PHOBOS

Management & DoE came to our rescue by not giving us enough money in the early phases of PHOBOS and thus prevented us from first using it at the AGS. However Management did give us enough to be ready on day one at RHIC.

13 June 2000:

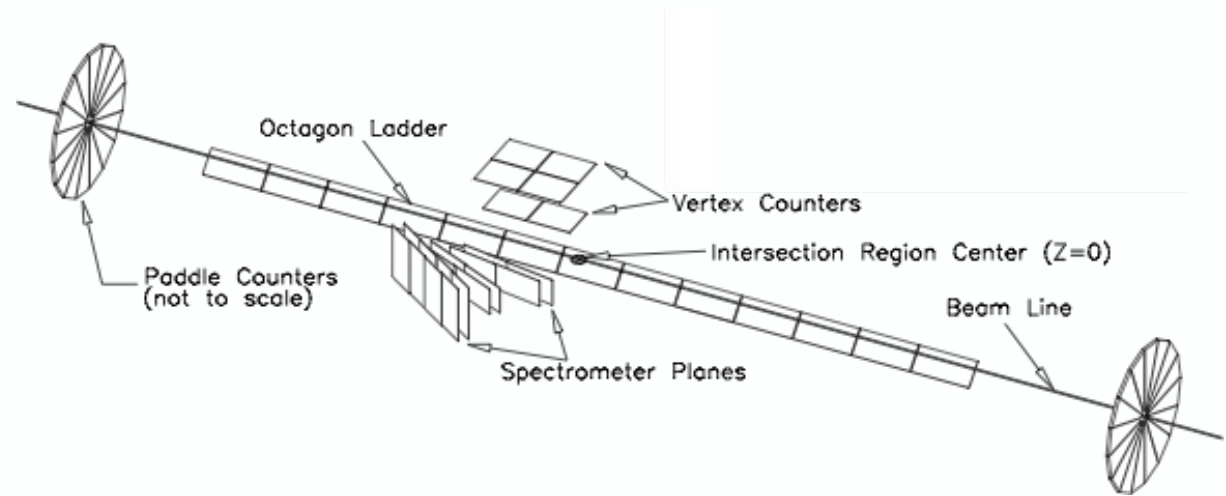

19 July 2000:

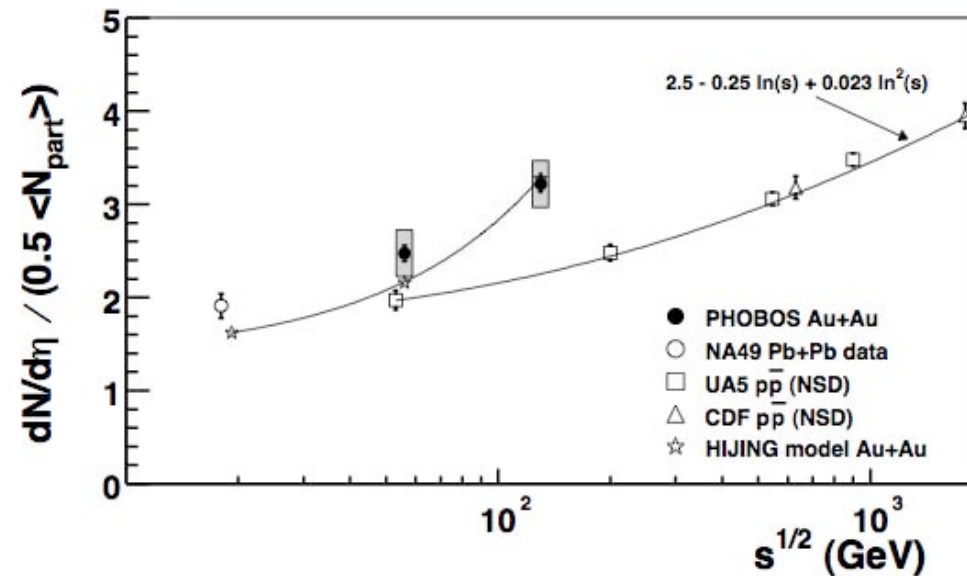

First result & it has withstood the test of time!

Pre-RHIC theoretical predictions

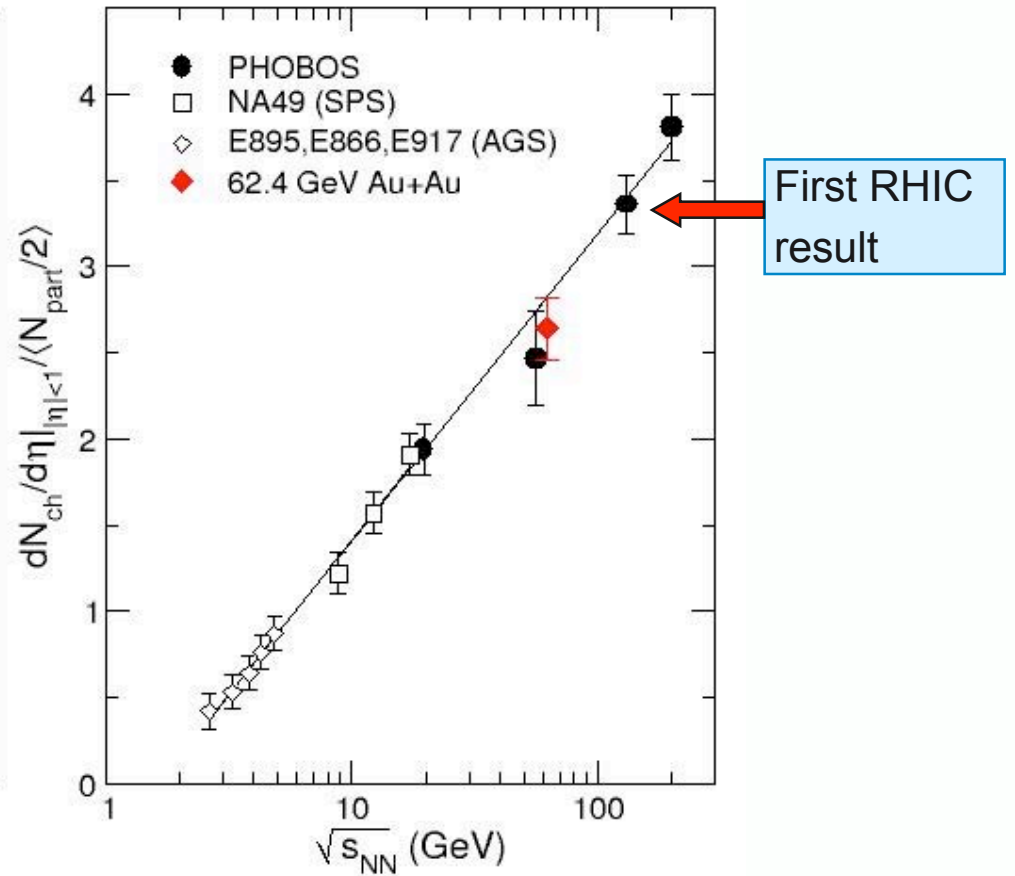
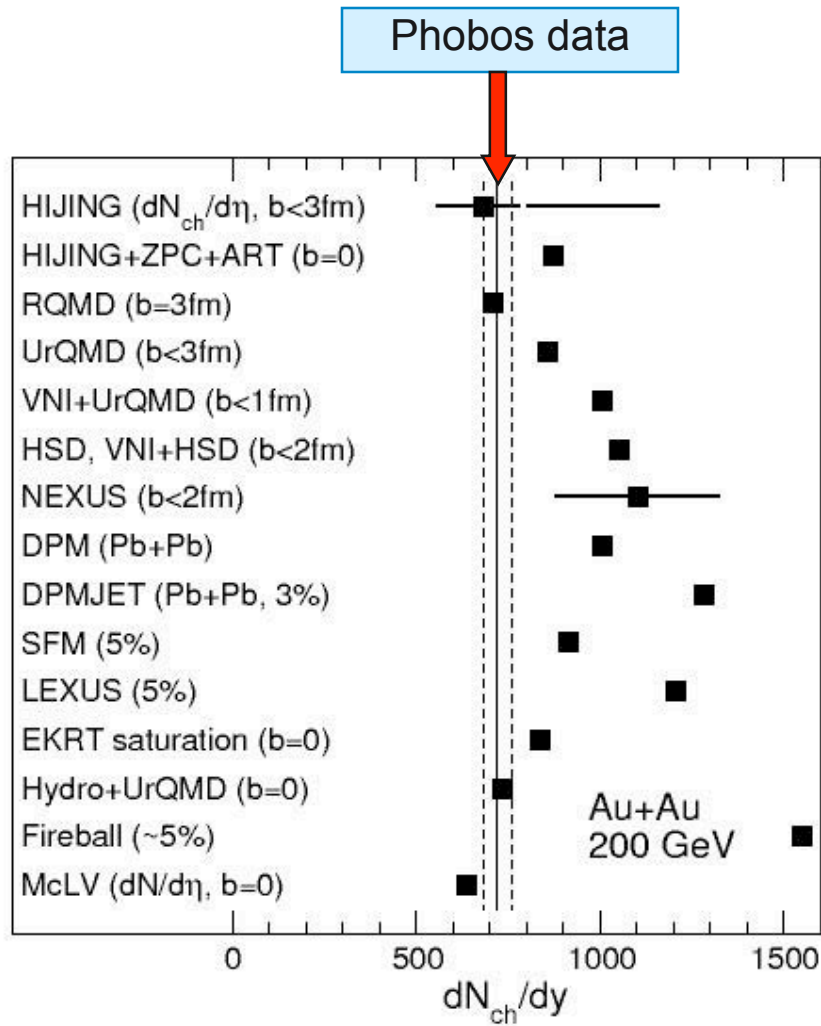

PHOBOS, Nucl. Phys. A747, 28 (2003)

PHOBOS Detector

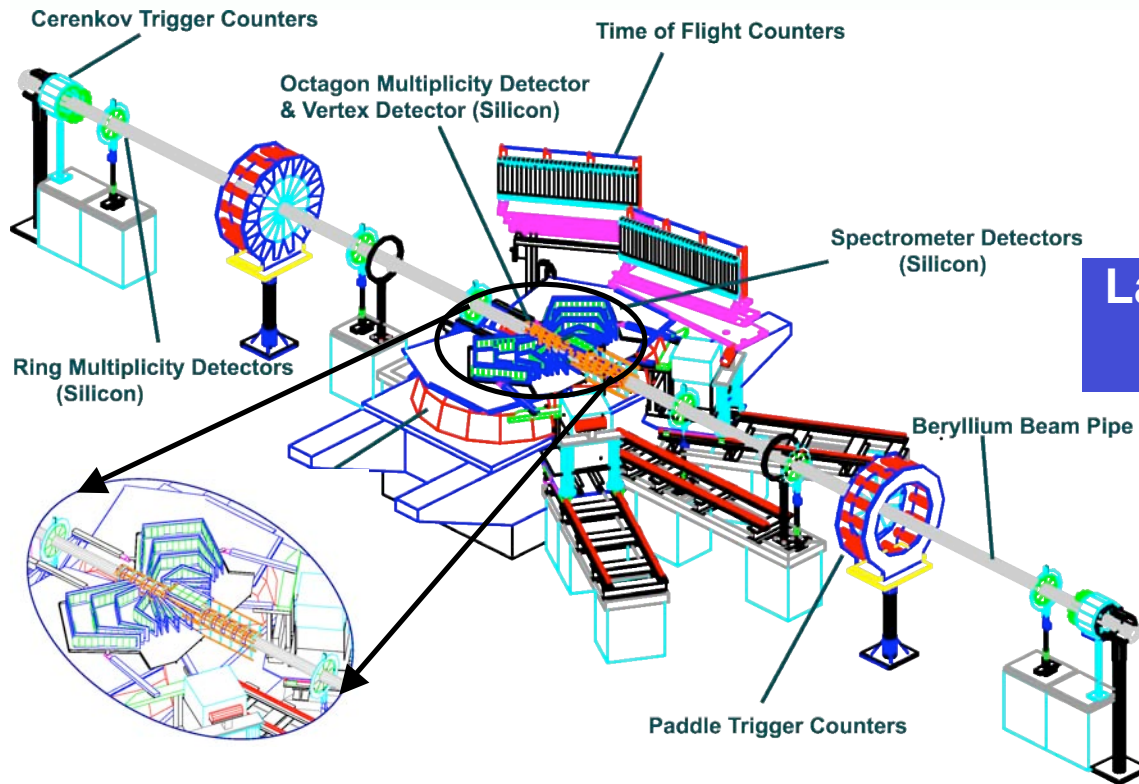

Large acceptance for N_{ch} $-5.4 < \eta < 5.4$
 $(0.5^\circ < \theta < 179.5^\circ) 0 < \phi < 2\pi$

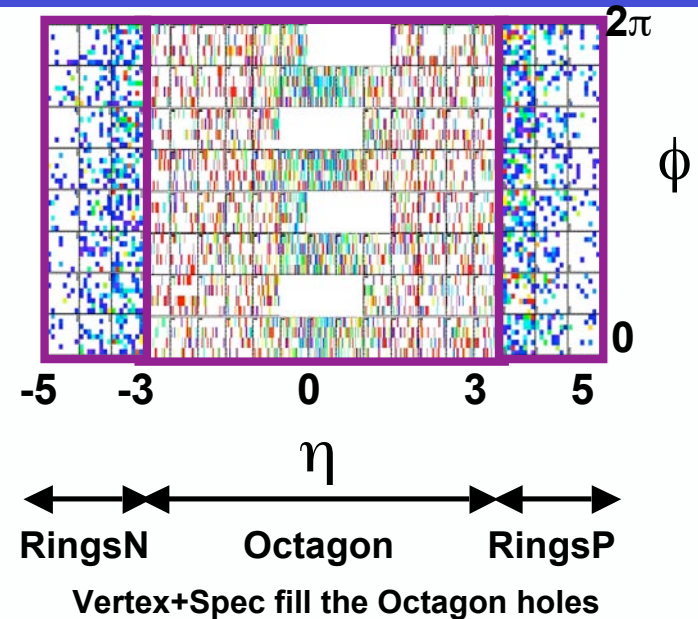

Unique low- p_T measurements

PHOBOS Collaboration



B.Alver, B.B.Back, M.D.Baker, M.Ballintijn, D.S.Barton, S.Basilev, R.Baum, B.Becker, R.R.Betts, A.A.Bickley, A.Białas, R.Bindel, W.Bogucki, A.Budzanowski, W.Busza*, A.Carroll, M. Ceglia, Z.Chai, Y.-H.Chang, A.E.Chen, V.Chetluru, T.Coghen, C.Conner, W.Czyż, B.Dąbrowski, M.P.Decowski, M.Despet, P.Fita, J.Fitch, M.Friedl, K.Gałaszka, R.Ganz, E.García, T.Gburek, N.George, J.Godlewski, C.Gomes, E.Griesmayer, K.Gulbrandsen, S.Gushue, J.Halik, C.Halliwell, J.Hamblen, P.Haridas, I.Harnarine, A.S.Harrington, M.Hauer, A.Hayes, G.A.Heintzelman, C.Henderson, D.J.Hofman, R.S.Hollis, R.Hołyński, B.Holzman, A.Iordanova, E.Johnson, J.L.Kane, J.Katzy, N.Khan, W.Kita, J.Kotuła, H.Kraner, W.Kucewicz, P.Kulinich, C.M.Kuo, C.Law, J.W.Lee, M.Lemler, W.Li, J.Ligocki, W.T.Lin, C.Loizides, S.Manly, D.McLeod, J.Michałowski, A.Mignerey, J.Mülmenstädt, M.Neal, R.Nouicer, A.Olszewski, R.Pak, I.C.Park, M.Patel, H.Pernegger, M.Plesko, C.Reed, L.P.Remsberg, M.Reuter, E.Richardson, C.Roland, G.Roland, D.Ross, L.Rosenberg, J.Ryan, J.Sagerer, A.Sanzgiri, P.Sarin, P.Sawicki, J.Scaduto, H.Seals, I.Sedykh, J.Shea, J.Sinacore, W.Skulski, C.E.Smith, M.A.Stankiewicz, S.G.Steadman, P.Steinberg, G.S.F.Stephans, A.Strączek, M.Stodulski, M.Stręk, Z.Stopa, A.Sukhanov, K.Surowiecka, A.Szostak, J.-L.Tang, R.Teng, M.B.Tonjes, A.Trzupek, C.Vale, G.J.van Nieuwenhuizen, S.S.Vaurynovich, R.Verdier, G.I.Veres, B.Wadsworth, P.Walters, E.Wenger, D.Willhelm, F.L.H.Wolfs, B.Wosiek, K.Woźniak, A.H.Wuosmaa, S.Wyngaardt, B.Wysłouch, K.Zalewski, J.Zhang, P.Żychowski

ARGONNE NATIONAL LABORATORY
INSTITUTE OF NUCLEAR PHYSICS PAN, KRAKOW
NATIONAL CENTRAL UNIVERSITY, TAIWAN
UNIVERSITY OF MARYLAND

BROOKHAVEN NATIONAL LABORATORY
MASSACHUSETTS INSTITUTE OF TECHNOLOGY
UNIVERSITY OF ILLINOIS AT CHICAGO
UNIVERSITY OF ROCHESTER

*spokesperson
Wit Busza

RHIC Users Meeting, May 2008

PHOBOS Achievements

- 4π coverage allowed unique study of global properties
- Discovery of simplicity and scaling of global properties
 - N_{part} scaling
 - Logarithmic rise of mid rapidity particle density
 - Extended longitudinal scaling of $dn/d\eta$ and v_2
- Observation that over entire RHIC energy range no signs of discontinuity in global observables
- No signs of increase in particle production at low p_T
- Extensive studies of correlations and fluctuations (still continuing), in particular related to eccentricity fluctuations
- Phobos results have been shown to be reliable.



PHOBOS Results on Pseudorapidity Distributions

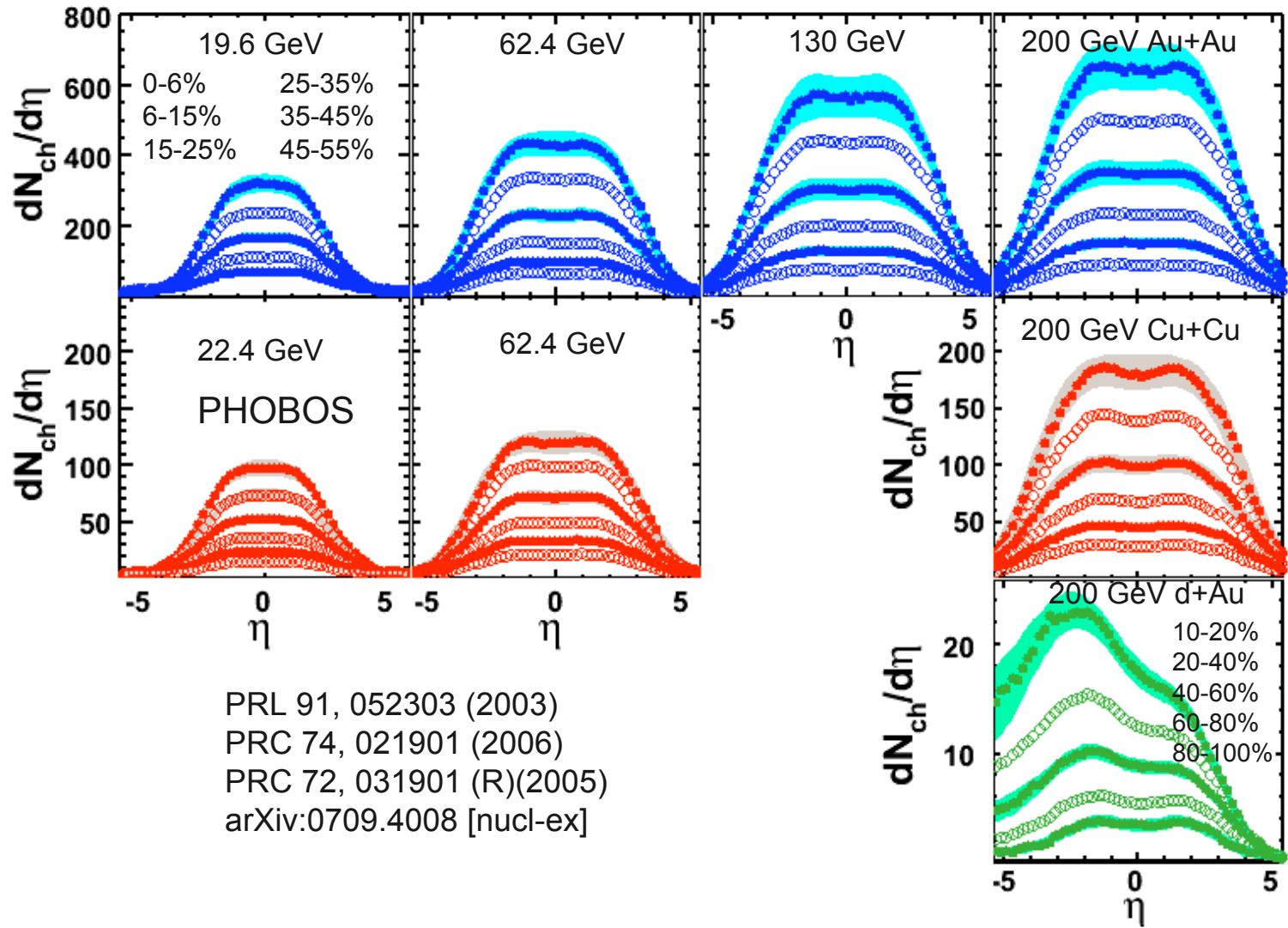

PRL 91, 052303 (2003)
 PRC 74, 021901 (2006)
 PRC 72, 031901 (R)(2005)
 arXiv:0709.4008 [nucl-ex]

Phobos results on elliptic flow of charged particles

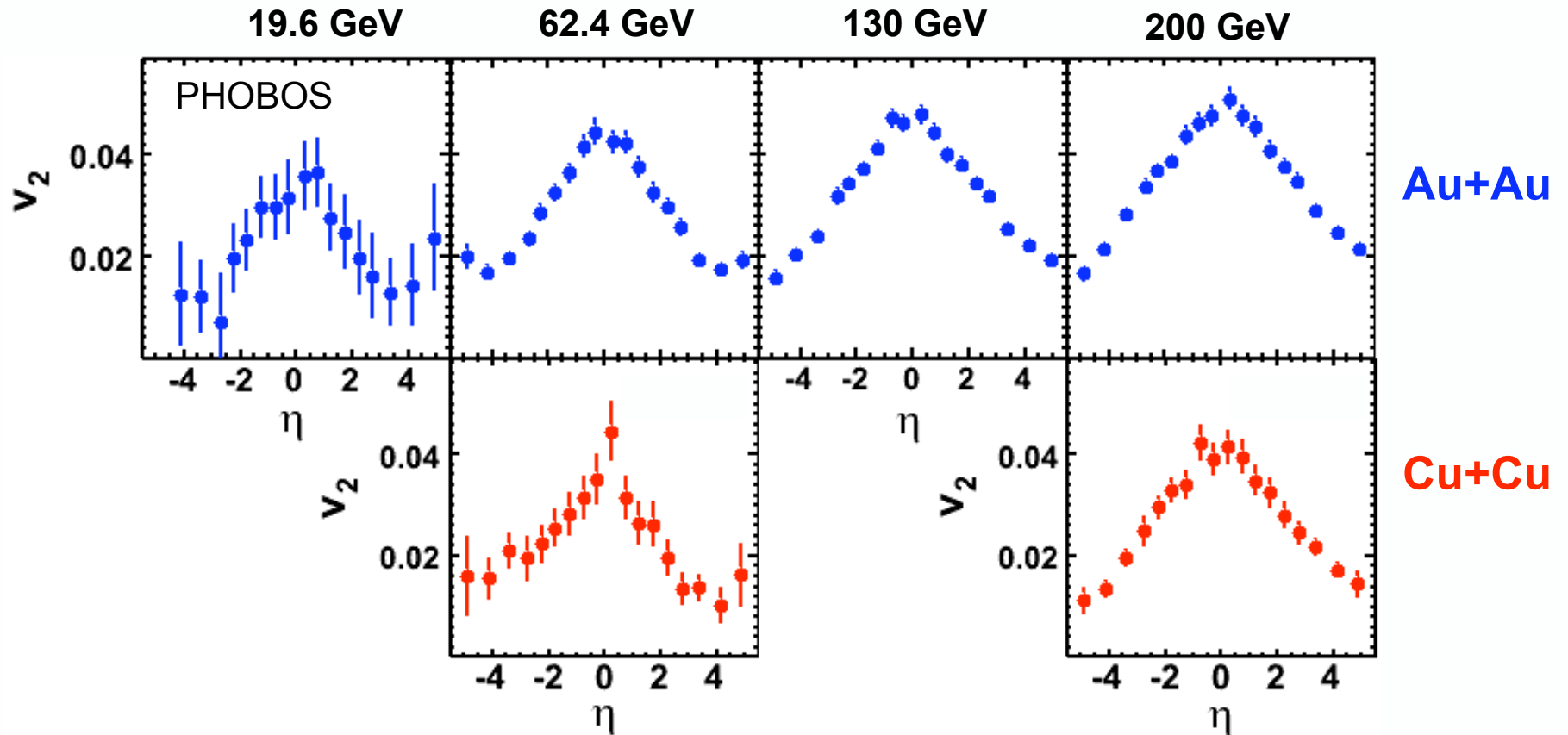

AuAu: PHOBOS: PRL 94 122303 (2005)
CuCu: PHOBOS: PRL 98, 242302 (2007)

Extended longitudinal scaling – Au+Au

PHOBOS Phys. Rev. Lett. 91, 052303 (2003) / Nucl. Phys. A757, 28 (2005)

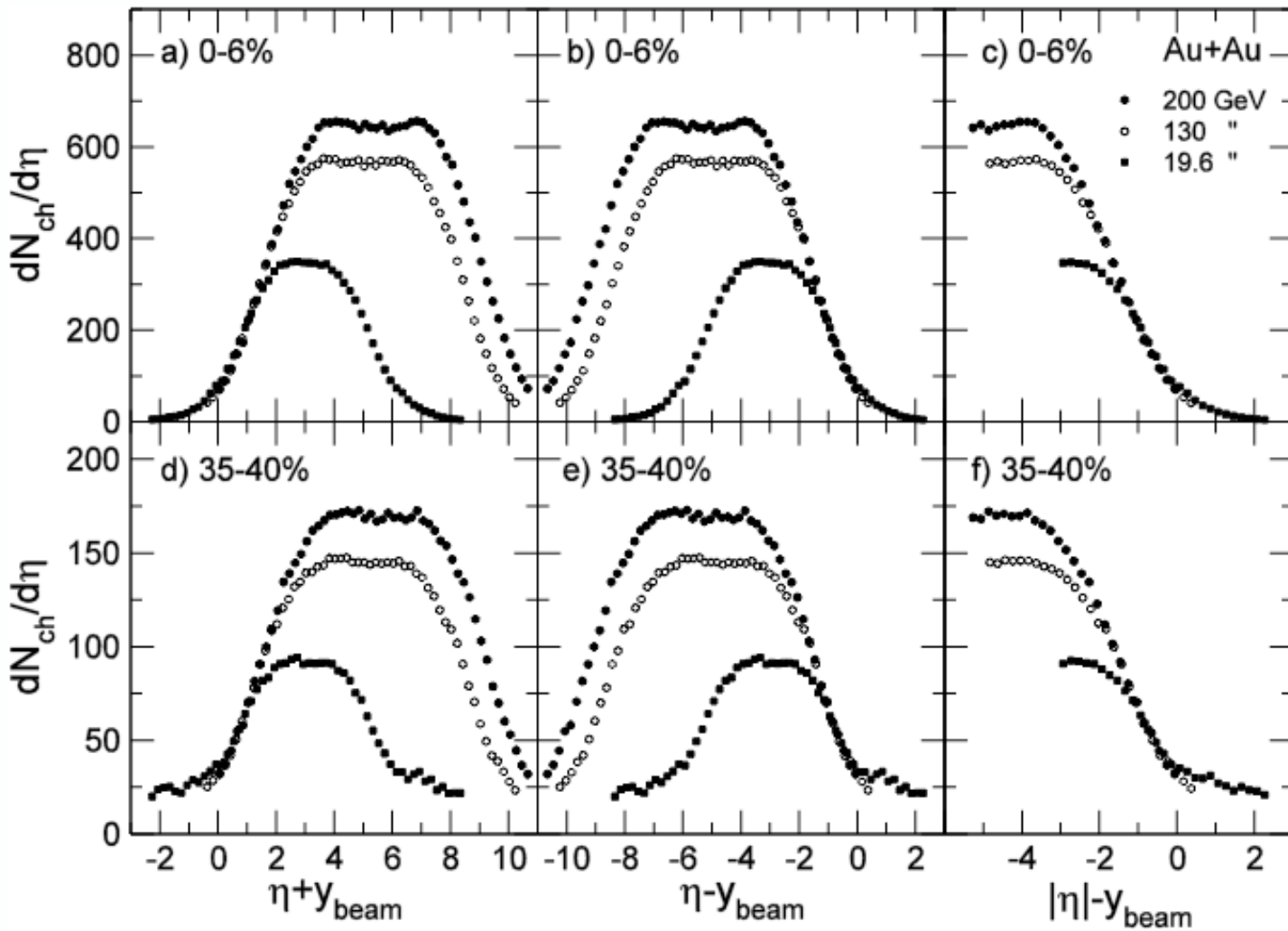

Extended longitudinal scaling – Au+Au, Cu+Cu, d+Au and p+A

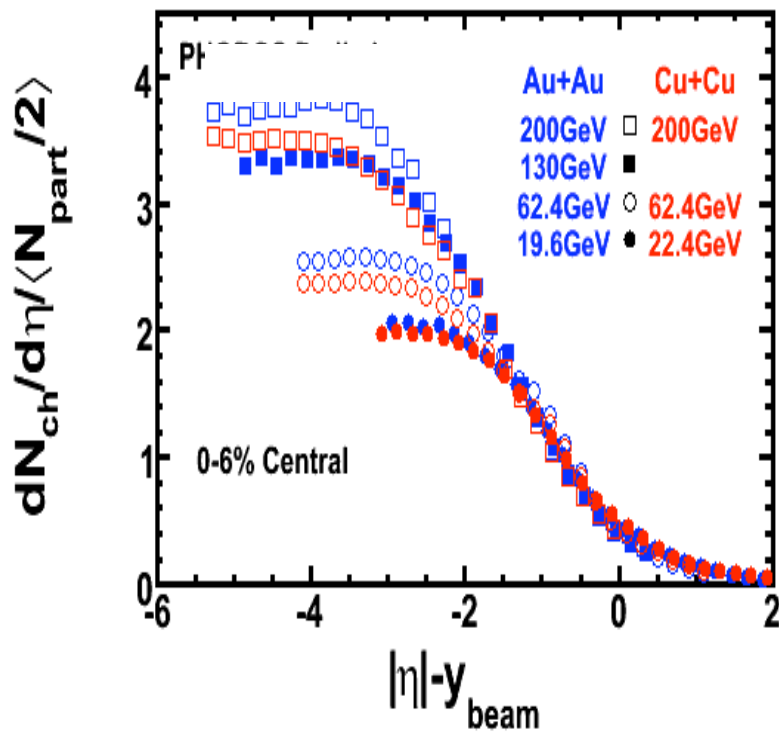

PHOBOS, arxiv:0709.4008 [nucl-ex]

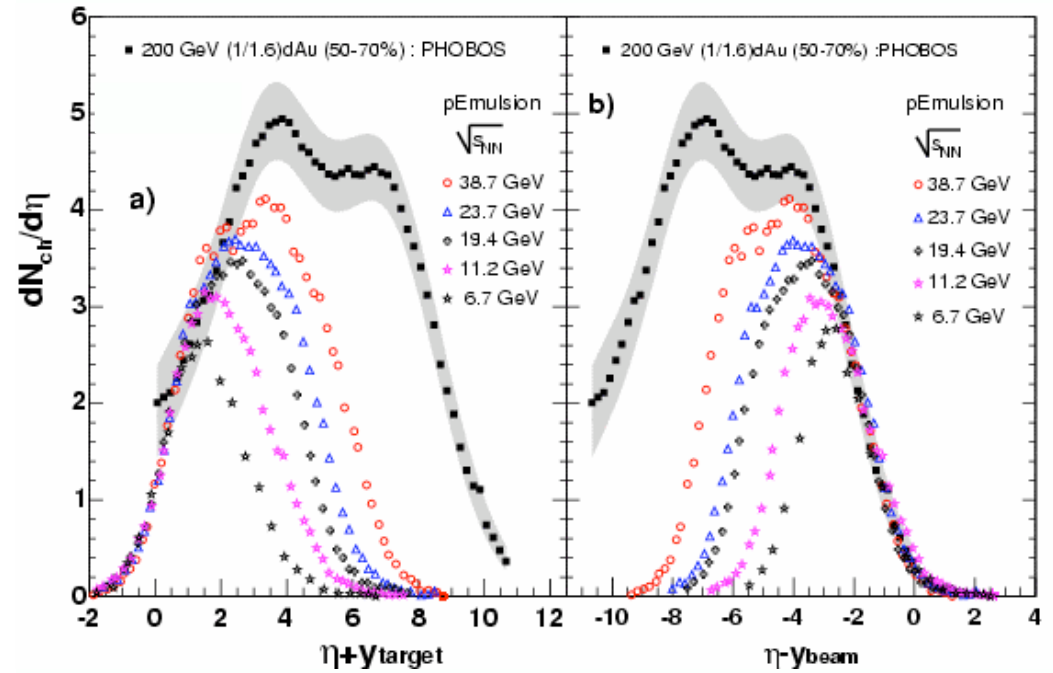

PHOBOS, Phys. Rev. C72, 031901(R) (2005)

Extended longitudinal scaling seen in elliptic flow!

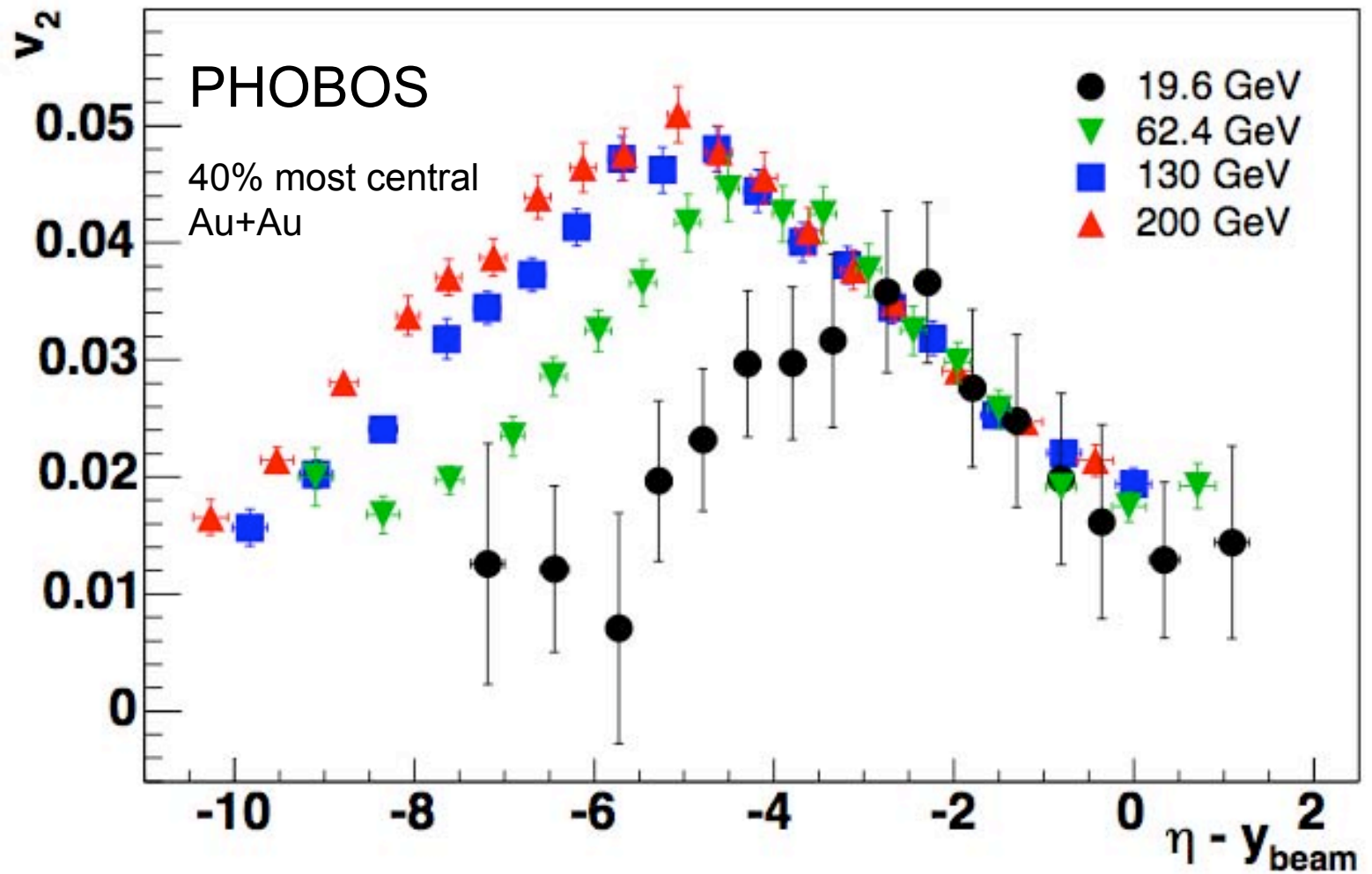

PHOBOS: PRL 94, 122303 (2005)

Factorization of centrality and energy dependence

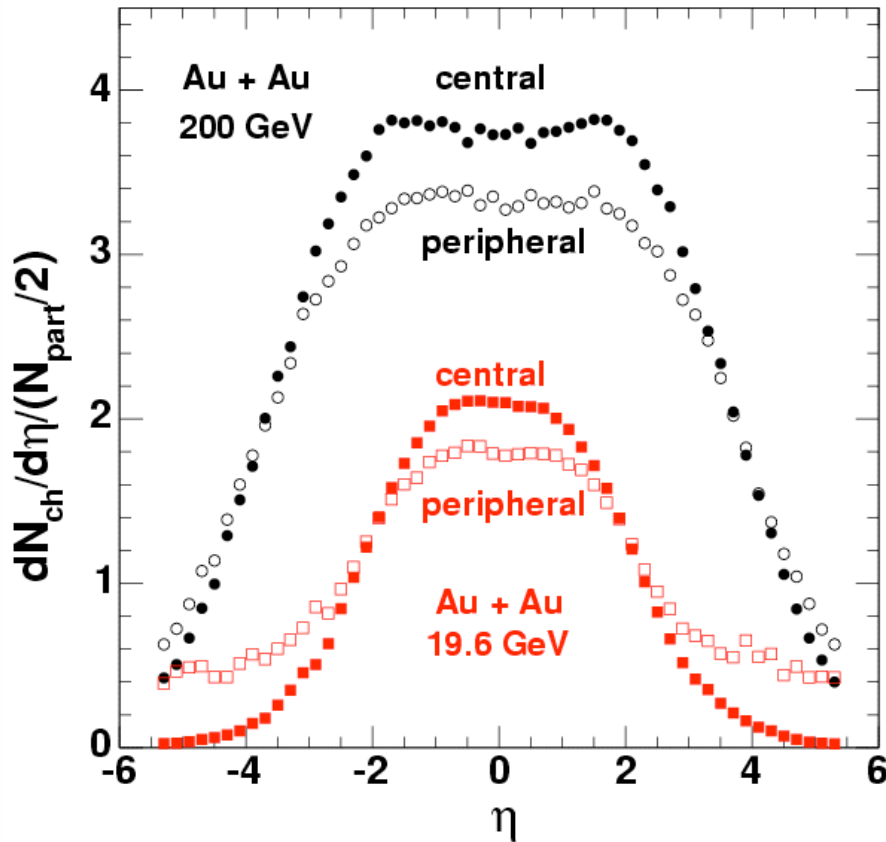

Nucl.Phys. A715 (2003) 65-74

PRL 91, 052303 (2003)

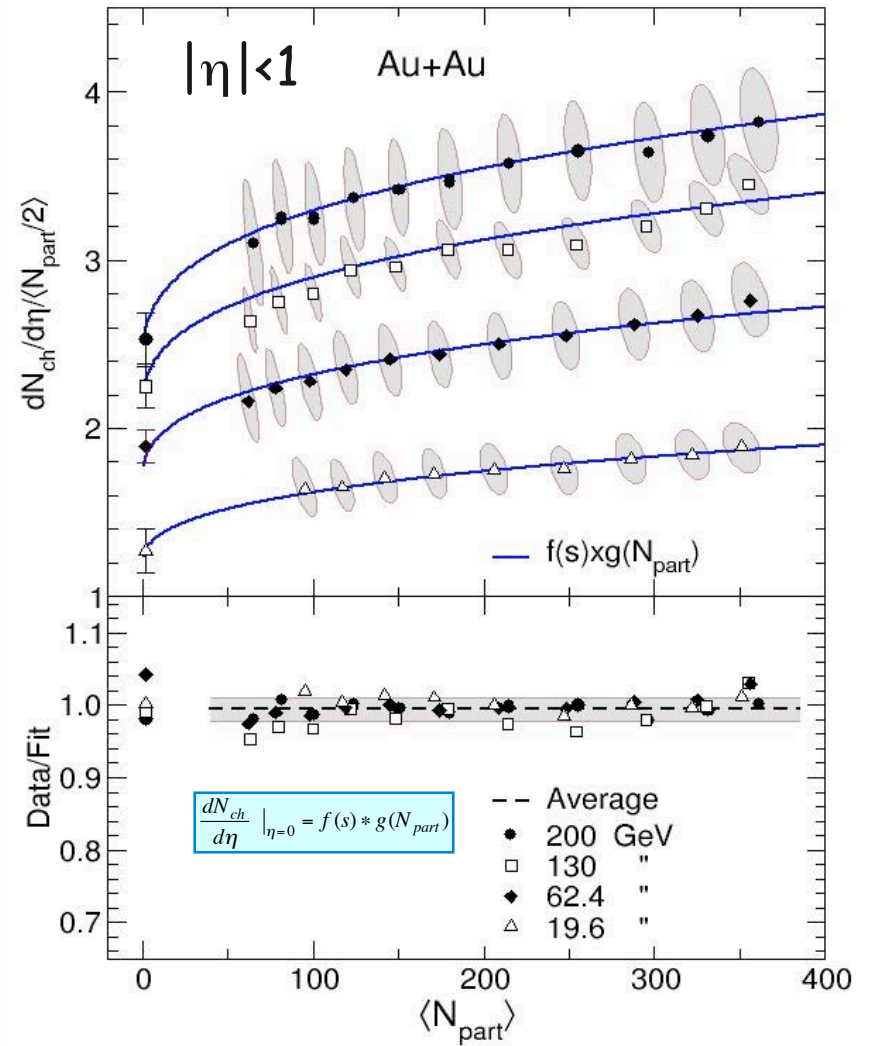

Data: PHOBOS, PRL 97, 012301 (2006);
 PRC70,021902(R) (2004);
 PRC65, 061901(R) (2002)

Figure: B.Back, Big Sky (2007)

N_{ch}^{Tot}

N_{part} Scaling holds in AA collisions

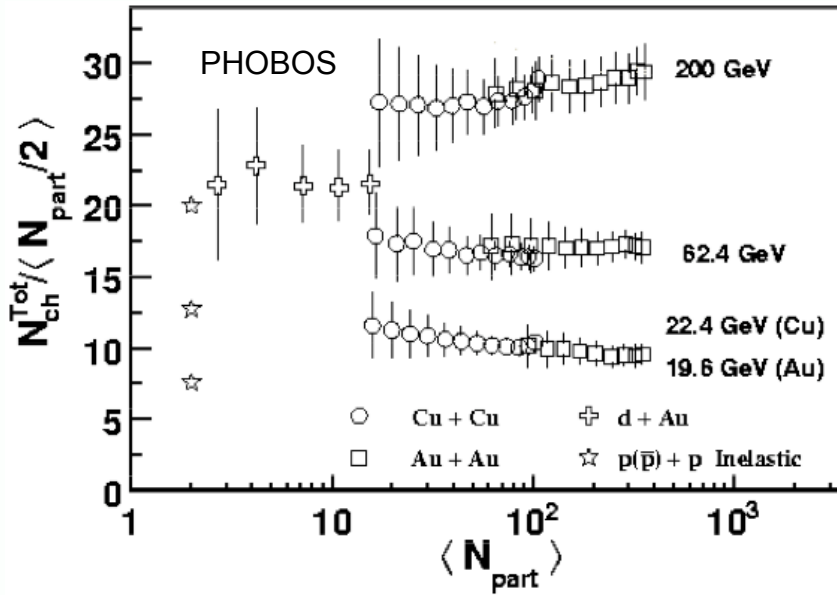

arXiv:0709.4008 [nucl-ex]

Universality of N_{ch}^{Tot}

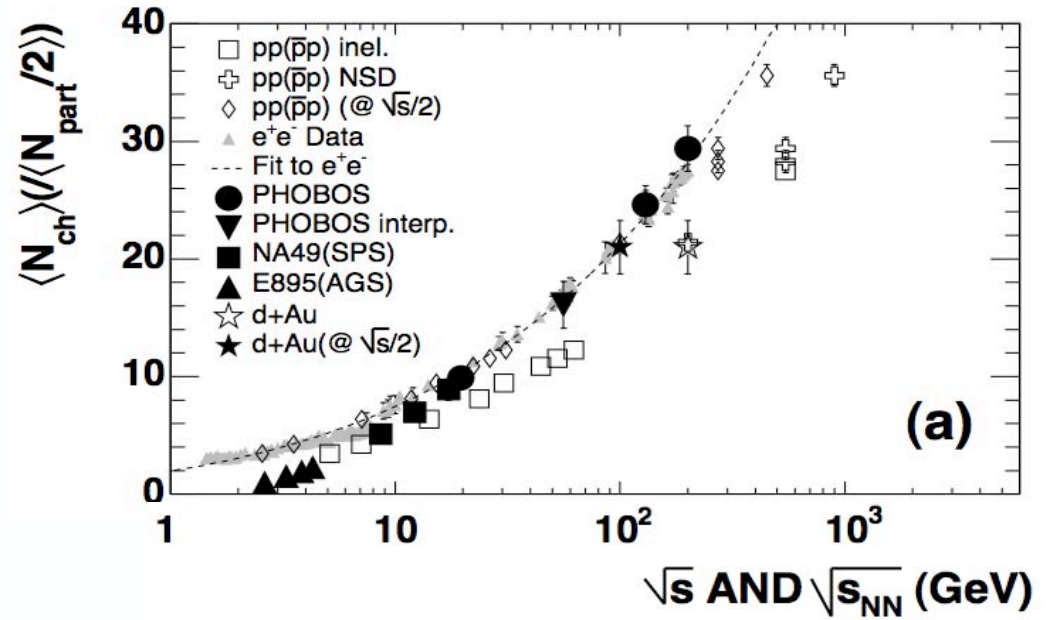

Antiparticle to particle ratios

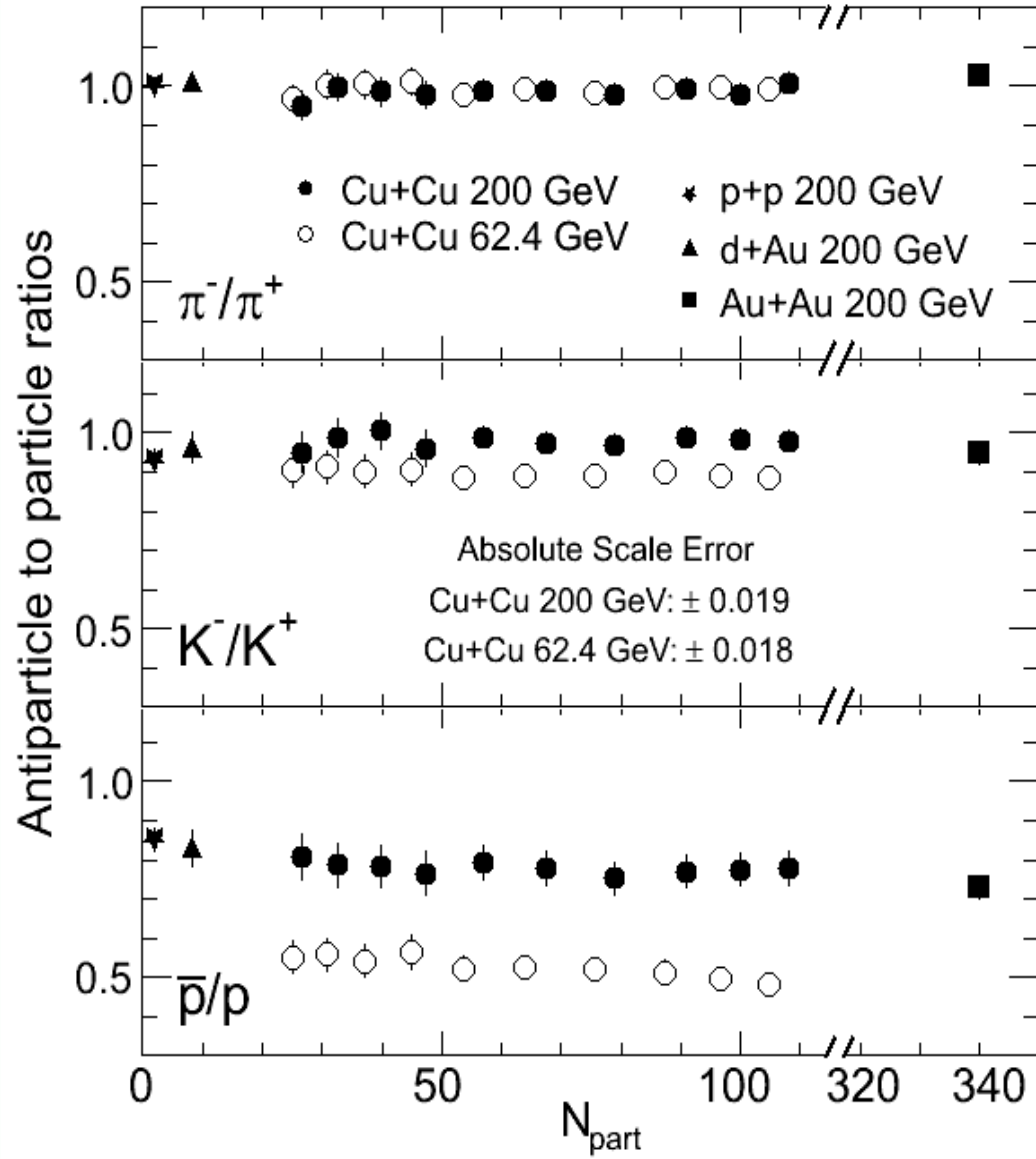

UNIQUE PHOBOS measurements on energy and centrality dependence of the low- p_T spectra

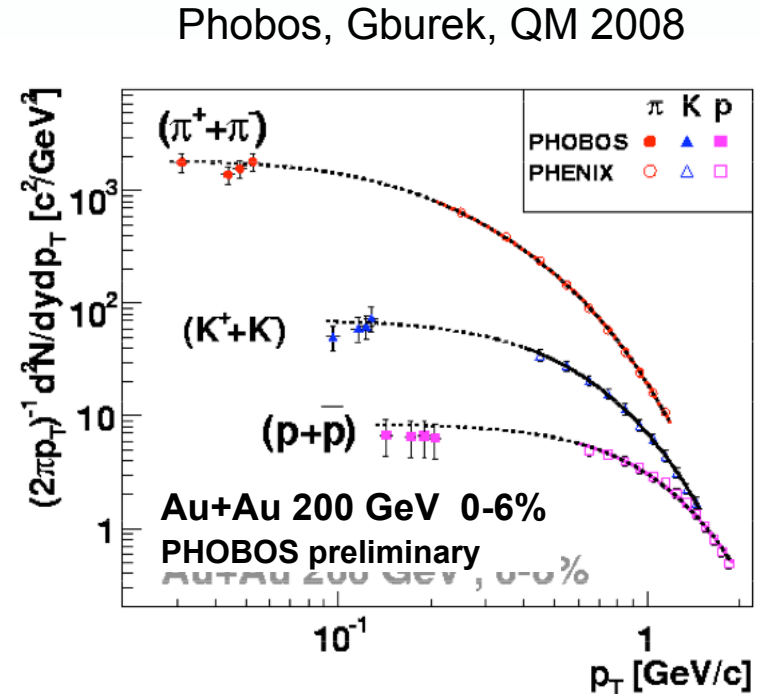
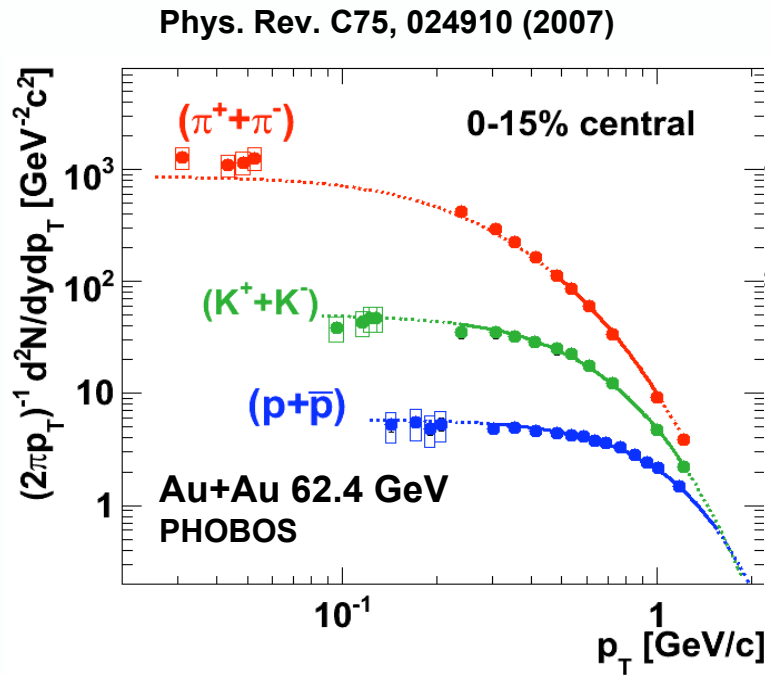

No anomalous low p_T enhancement

PHOBOS RESULTS THAT WILL HAVE LASTING VALUE AND WHICH NEED TO BE UNDERSTOOD AND EXPLAINED

- 1. Simplicity and universality of Global Data - often data is simpler than the explanations!**
- 2. Geometry of the collision plays a crucial role in determining a surprising number of particle production properties**
- 3. Many phenomena can be factorized into an energy and centrality part**
- 4. Number of participants plays a crucial role in determining the integral of the distributions (participant scaling)**
- 5. Extended longitudinal scaling (including v_2)**
- 6. Importance of participant eccentricity in determining flow**



CURRENT PHASE OF PHOBOS

STUDY OF FLUCTUATIONS AND CORRELATIONS

PHOBOS Flow Fluctuation Studies

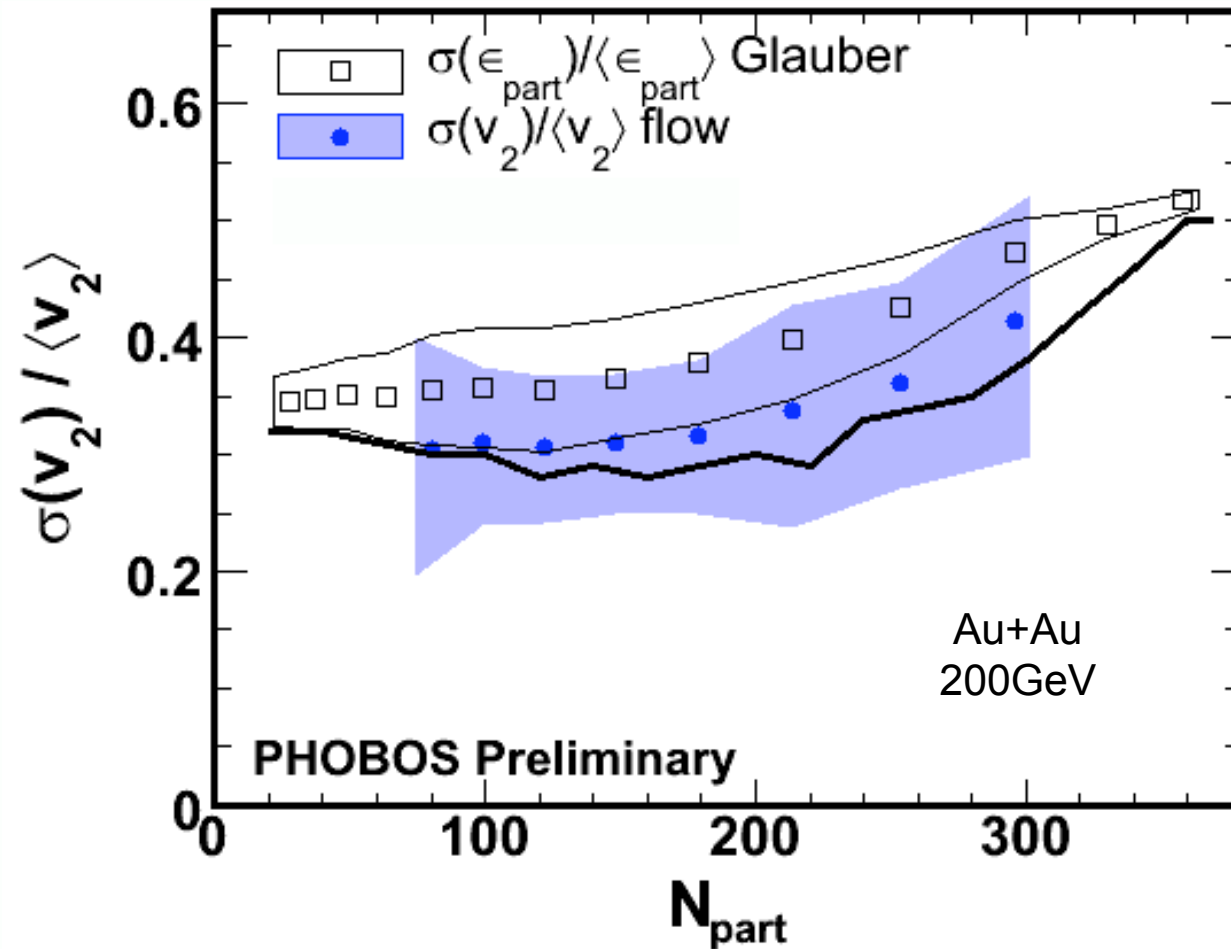

$$\epsilon_{\text{part}} = \frac{\sqrt{(\sigma_y^2 - \sigma_x^2)^2 + 4\sigma_{xy}^2}}{\sigma_x^2 + \sigma_y^2}$$

Phobos Studies of Two-Particle Correlations

$$R(\Delta\eta, \Delta\phi) = \langle (n-1) \left(\frac{F_n(\Delta\eta, \Delta\phi)}{B_n(\Delta\eta, \Delta\phi)} - 1 \right) \rangle$$

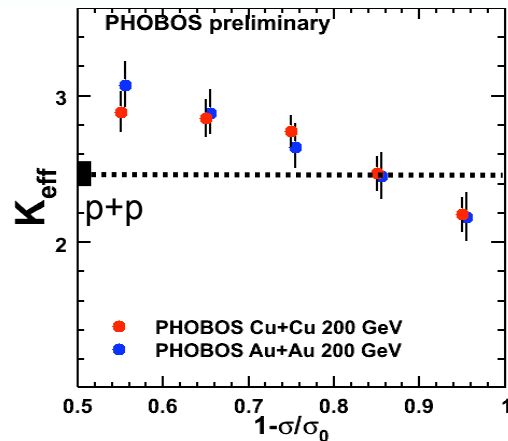
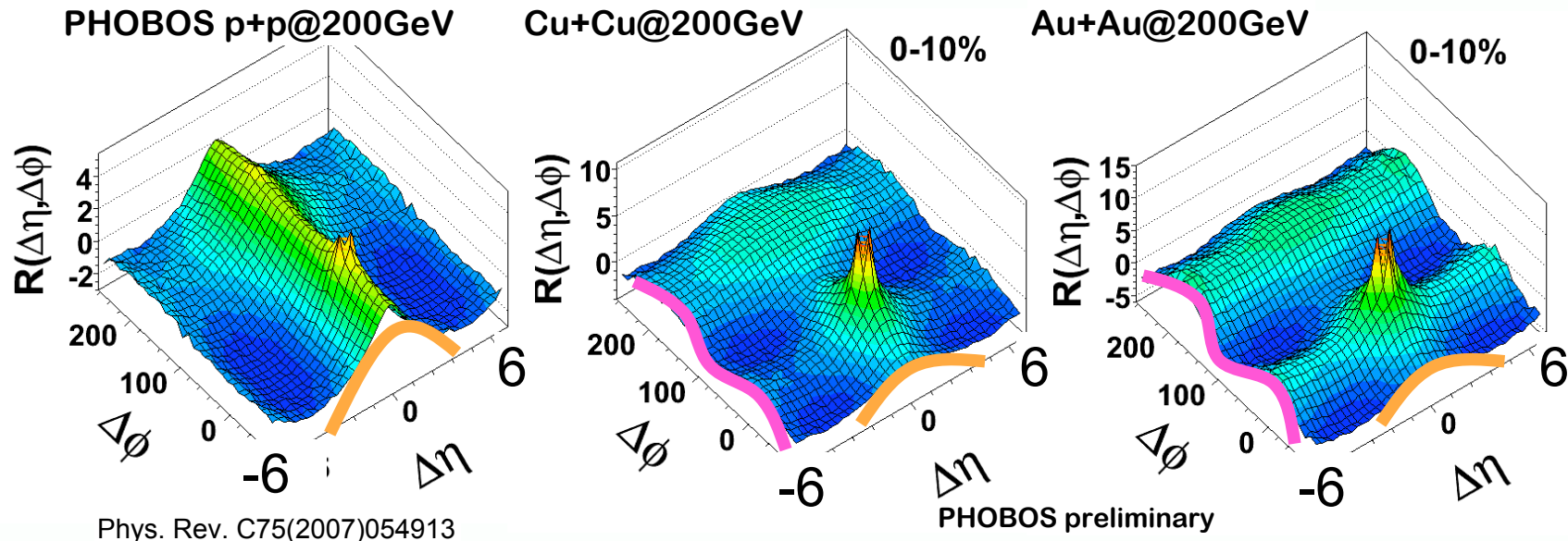

Phobos Ridge Studies

$$\frac{1}{N_{\text{trig}}} \frac{d^2 N_{\text{ch}}}{d\Delta\phi d\Delta\eta} = \mathbf{B}(\Delta\eta) \left[\frac{s(\Delta\phi, \Delta\eta)}{b(\Delta\phi, \Delta\eta)} - a \cdot 1 + 2V(\Delta\eta) \cos(2\Delta\phi) \right]$$

$\frac{1}{N_{\text{trig}}} \frac{d^2 N_{\text{ch}}}{d\Delta\phi d\Delta\eta}$ Au+Au 0-30% central
PHOBOS preliminary

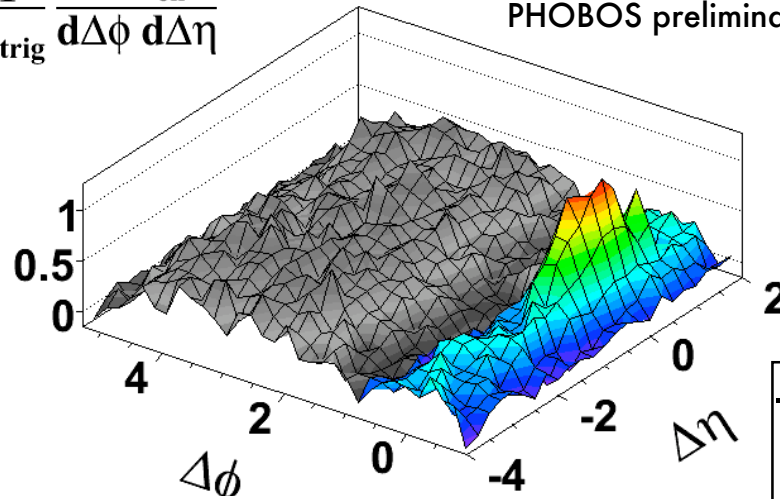

$p_{\text{T}}^{\text{trig}} > 2.5 \text{ GeV}/c$
 $p_{\text{T}}^{\text{assoc}} \geq 20 \text{ MeV}/c$

$-4 < \Delta\eta < -2$
 $|\Delta\phi| < 1$

Near-side
 $|\Delta\phi| < 1$

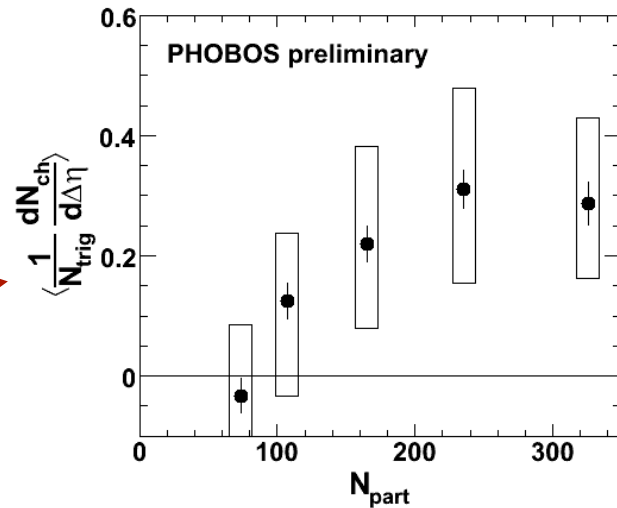
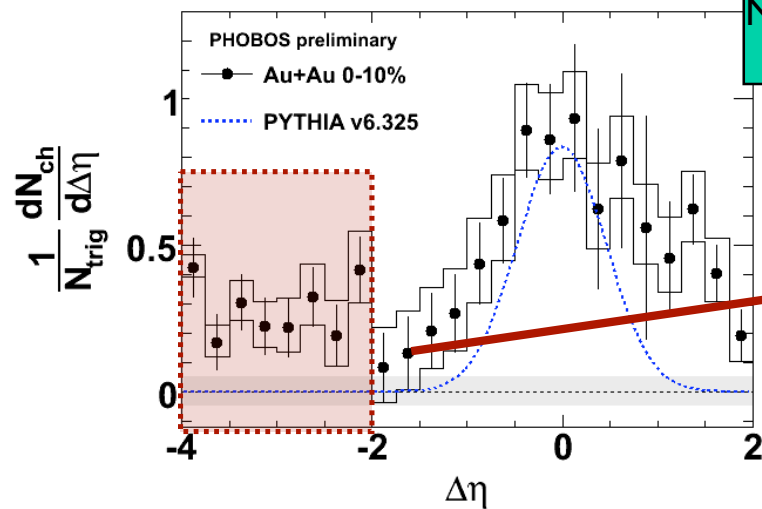

W

May 2008

Summary

Phobos refereed publications

PRL - 13
PRC (RC) - 14
PRC - 4
Phys Lett - 1
Nucl Phys A - 1
Physics total - 33

NIM - 7

PHOBOS citations

Total = 2152
1 Famous (>250)
8 Very well-known (>100)
5 well-known (>50)

Phobos graduate students

Completed Ph.D. - 14

A. Bickley
P. Decowski
K. Gulbrandsen
J. Hamblen
C. Henderson
R. Hollis
A. Iordanova
E. Johnson
J. Kane
C-M Kuo
C. Reed
M. Reuter
P. Sarin
C. Vale

Current - 9

B. Alver
R. Bindel
V. Chetluru
T. Gburek
W. Li
J. Sagerer
S. Vaurynovich
P. Walters
E. Wenger

We wish to thank

- RHIC management
- RHIC Accelerator & RCF staff
- DoE

For all the help and support you have given to PHOBOS.

Where is the PHOBOS detector now?

